

## 3" Straight Section

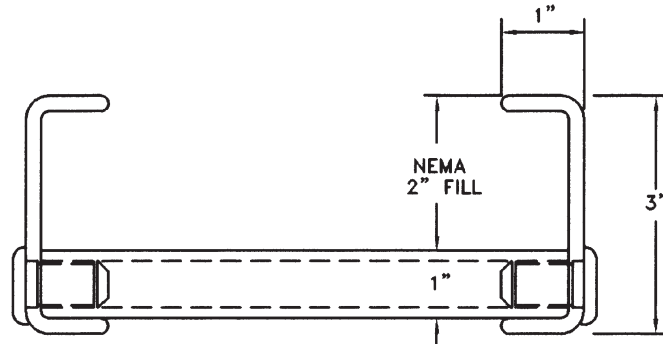

**Side Rail Height:** 3" (NEMA 2" loading depth)

**Widths:** 6", 9", 12", 18", 24"

**Rung Spacing:** 6", 9", 12", 18"

**Length:** 120" (10') or 240" (20')

**Splice Plates:** One pair of splice plates with SS6 (316 Stainless Steel) hardware included.

3" System

Seasafe Series	Safety Factor
3	1.5

**Loading - NEMA 8C \* tested per NEMA FG-1, 12" rung spacing**

# 3" Horizontal Bends

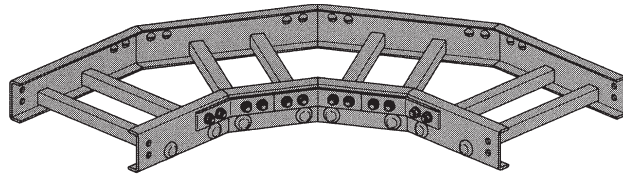

One pair of splice plates with SS6 hardware

-R- Bend Radius in.	Tray Width in.	90° Horizontal Bend Dimensions		
		Catalog No.	A in.	B in.
12	6	(Prefix)-06-90HB12	20 3/8	20 3/8
	9	(Prefix)-09-90HB12	21 7/8	21 7/8
	12	(Prefix)-12-90HB12	23 3/8	23 3/8
	18	(Prefix)-18-90HB12	26 3/8	26 3/8
	24	(Prefix)-24-90HB12	29 3/8	29 3/8

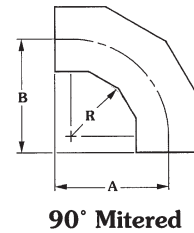

-R- Bend Radius in.	Tray Width in.	45° Horizontal Bend Dimensions			
		Catalog No.	A in.	B in.	C in.
12	6	(Prefix)-06-45HB12	22 13/16	9 7/16	13 3/8
	9	(Prefix)-09-45HB12	23 7/8	9 7/8	14
	12	(Prefix)-12-45HB12	24 7/8	10 5/16	14 5/8
	18	(Prefix)-18-45HB12	27	11 3/16	15 7/8
	24	(Prefix)-24-45HB12	29 3/16	12 1/16	17 1/8

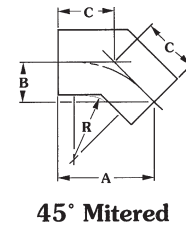

Note: Dimensions for reference only, when critical contact factory.

# 3" Horizontal Tee

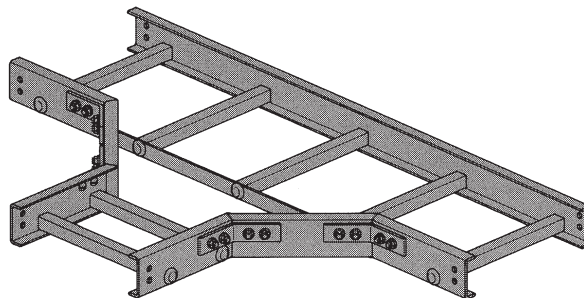

Two pair of splice plates with SS6 hardware included.

-R- Bend Radius in.	Tray Width in.	Horizontal Tee Dimensions		
		Catalog No.	A in.	B in.
12	6	(Prefix)-06-HT12	19 1/4	38
	9	(Prefix)-09-HT12	20 3/4	41 1/2
	12	(Prefix)-12-HT12	22 1/4	44 1/2
	18	(Prefix)-18-HT12	25 1/4	50 1/2
	24	(Prefix)-24-HT12	28 1/4	56 1/2

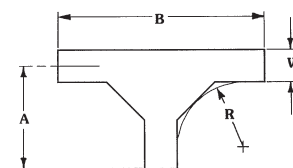

Note: Dimensions for reference only, when critical contact factory.

# 3" Vertical Bends

**Outside Vertical Bend**  
VO

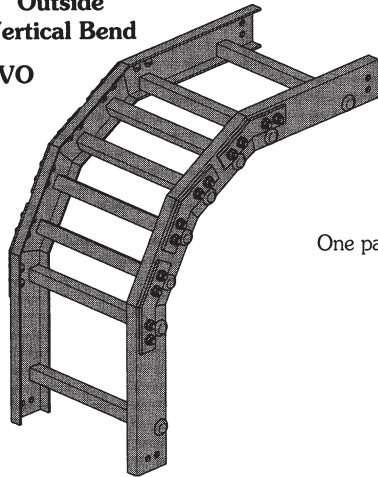

**Inside Vertical Bend**  
VI

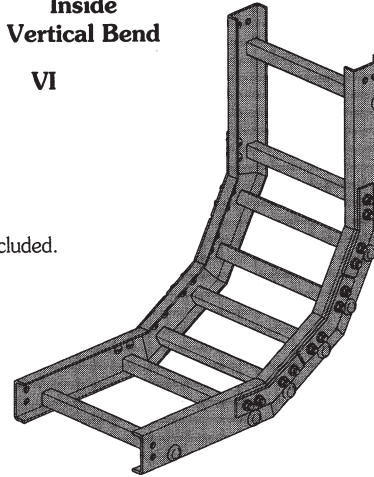

One pair of splice plates with SS6 hardware included.

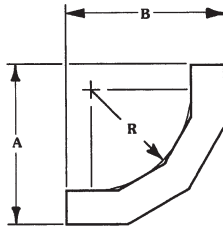

90° Mitered

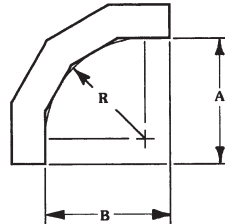

90° Mitered

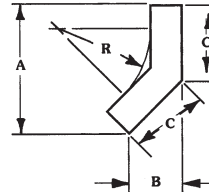

45° Mitered

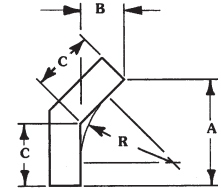

45° Mitered

3" System

-R- Bend Radius in.	Tray Width in.	Catalog No.	90°			
			Vertical Outside Bend		Vertical Inside Bend	
			A in.	B in.	A in.	B in.
12	6	(Prefix)-06-90(*)12	20 15/16	20 15/16	26 15/16	26 15/16
	9	(Prefix)-09-90(*)12				
	12	(Prefix)-12-90(*)12				
	18	(Prefix)-18-90(*)12				
	24	(Prefix)-24-90(*)12				

-R- Bend Radius in.	Tray Width in.	Catalog No.	45°					
			Vertical Outside Bend			Vertical Inside Bend		
			A in.	B in.	C in.	A in.	B in.	C in.
12	6	(Prefix)-06-45(*)12	20 1/2	8 1/2	13 1/4	22 5/8	9 3/8	13 1/4
	9	(Prefix)-09-45(*)12						
	12	(Prefix)-12-45(*)12						
	18	(Prefix)-18-45(*)12						
	24	(Prefix)-24-45(*)12						

**Note:** Dimensions for reference only, when critical contact factory.

# 3" Horizontal Cross

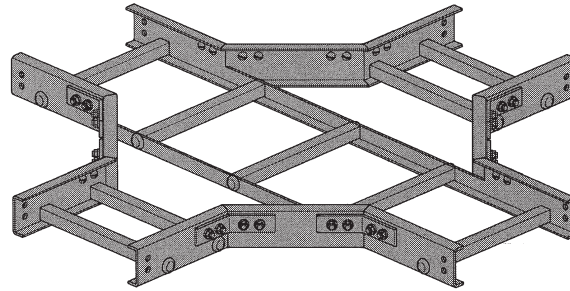

Three pair of splice plates with SS6 hardware included.

-R- Bend Radius in.	Tray Width in.	Horizontal Bend Dimensions		
		Catalog No.	A in.	B in.
12	6	(Prefix)-06-45HX12	19 1/4	38 1/2
	9	(Prefix)-09-45HX12	20 3/4	41 1/2
	12	(Prefix)-12-45HX12	22 1/4	44 1/2
	18	(Prefix)-18-45HX12	25 1/4	50 1/2
	24	(Prefix)-24-45HX12	28 1/4	56 1/2

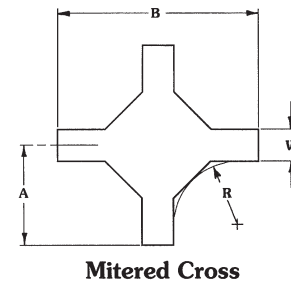

**Note:** Dimensions for reference only, when critical contact factory.

# 3" Reducers

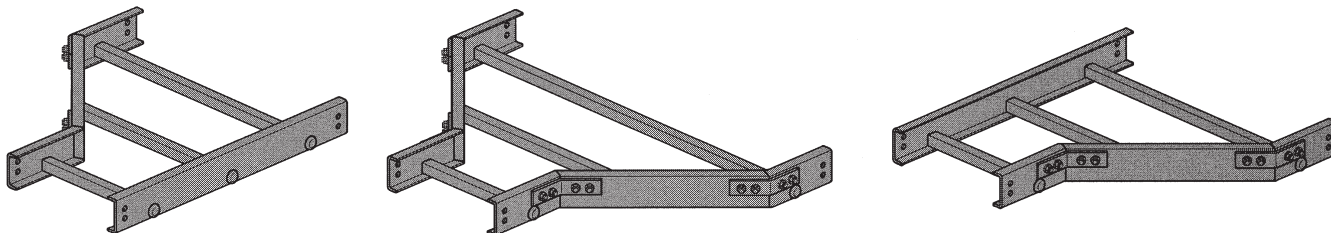

One pair of splice plates with SS6 hardware included.

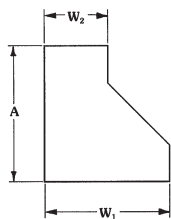

**Left Hand Reducer**

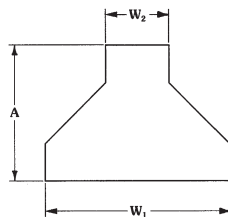

**Straight Reducer**

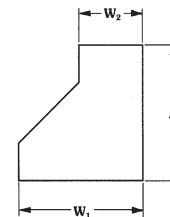

**Right Hand Reducer**

Tray Width		Left Hand Reducer		Straight Reducer		Right Hand Reducer	
W1 in.	W2 in.	Catalog No.	A in.	Catalog No.	A in.	Catalog No.	A in.
9	6	(Prefix)-09-LR06	17 1/2	(Prefix)-09-SR06	16	(Prefix)-09-RR06	17 1/2
12	6	(Prefix)-12-LR06	20 1/2	(Prefix)-12-SR06	17 1/2	(Prefix)-12-RR06	20 1/2
	9	(Prefix)-12-LR09	17 1/2	(Prefix)-12-SR09	16	(Prefix)-12-RR09	17 1/2
18	6	(Prefix)-18-LR06	26 1/2	(Prefix)-18-SR06	20 1/2	(Prefix)-18-RR06	26 1/2
	9	(Prefix)-18-LR09	23 1/2	(Prefix)-18-SR09	19	(Prefix)-18-RR09	23 1/2
	12	(Prefix)-18-LR12	20 1/2	(Prefix)-18-SR12	17 1/2	(Prefix)-18-RR12	20 1/2
24	6	(Prefix)-24-LR06	32 1/2	(Prefix)-24-SR06	23 1/2	(Prefix)-24-RR06	32 1/2
	9	(Prefix)-24-LR09	29 1/2	(Prefix)-24-SR09	22	(Prefix)-24-RR09	29 1/2
	12	(Prefix)-24-LR12	26 1/2	(Prefix)-24-SR12	20 1/2	(Prefix)-24-RR12	26 1/2
	18	(Prefix)-24-LR18	20 1/2	(Prefix)-24-SR18	17 1/2	(Prefix)-24-RR18	20 1/2

**Note:** Dimensions for reference only, when critical contact factory.

# 3" Horizontal Expanding/Reducing Cross

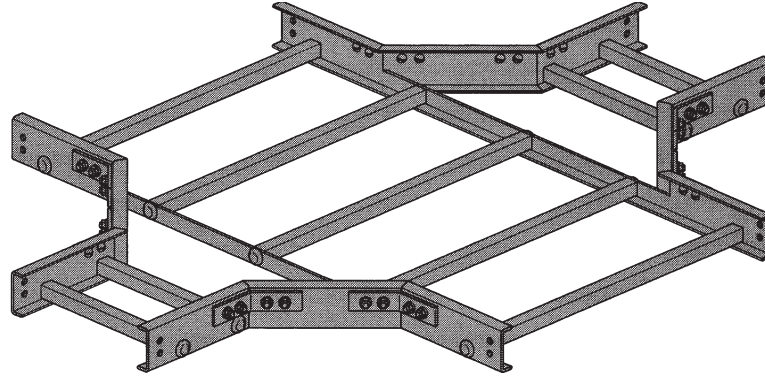

Three pair of splice plates with SS6 hardware included.

Tray Width		Catalog No.	12" Radius	
W1 in.	W2 in.		A in.	B in.
9	6	(Prefix)-09-06-HX12	19 1/4	41 1/2
12	6	(Prefix)-12-06-HX12	19 1/4	44 1/2
	9	(Prefix)-12-09-HX12	20 3/4	44 1/2
18	6	(Prefix)-18-06-HX12	19 1/4	50 1/2
	9	(Prefix)-18-09-HX12	20 3/4	50 1/2
	12	(Prefix)-18-12-HX12	22 1/4	50 1/2
24	6	(Prefix)-24-06-HX12	19 1/4	56 1/2
	9	(Prefix)-24-09-HX12	20 3/4	56 1/2
	12	(Prefix)-24-12-HX12	22 1/4	56 1/2
	18	(Prefix)-24-18-HX12	25 1/4	56 1/2

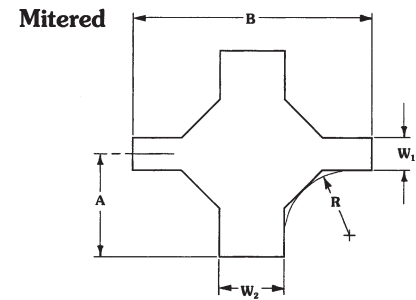

**Note:** Dimensions for reference only, when critical contact factory.

3" System

# 3" Vertical Tees

Vertical Tee Down

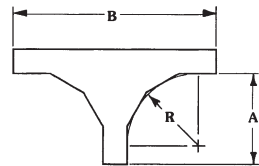

Mitered

Vertical Tee Up

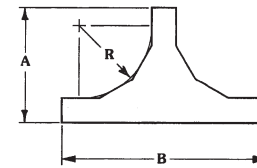

Mitered

Two pair of splice plates with SS6 hardware included.

-R- Bend Radius in.	Tray Width in.	Catalog No.	Vertical Tees			
			Vertical Tee Down		Vertical Tee Up	
			A in.	B in.	A in.	B in.
12	6	(Prefix)-06-(*)12	23 15/16	50 7/8	26 15/16	50 7/8
	9	(Prefix)-09-(*)12				
	12	(Prefix)-12-(*)12				
	18	(Prefix)-18-(*)12				
	24	(Prefix)-24-(*)12				

**Note:** Dimensions for reference only, when critical contact factory.

### 3" Horizontal Reducing Tee

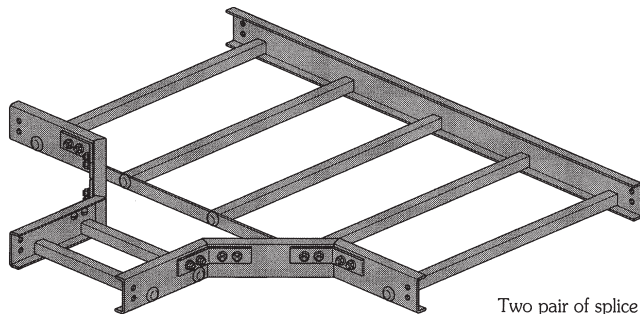

Two pair of splice plates with SS6 hardware included

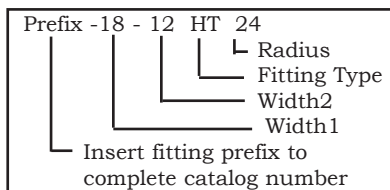
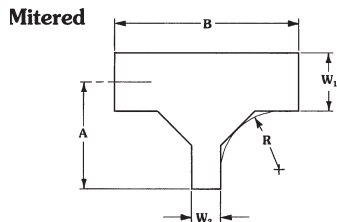

Tray Width		Catalog No.	12" Radius	
W1 in.	W2 in.		A in.	B in.
9	6	(Prefix)-09-06-HT12	20 3/4	38 1/2
12	6	(Prefix)-12-06-HT12	22 1/4	38 1/2
	9	(Prefix)-12-09-HT12	22 1/4	41 1/2
18	6	(Prefix)-18-06-HT12	25 1/4	38 1/2
	9	(Prefix)-18-09-HT12	25 1/4	41 1/2
	12	(Prefix)-18-12-HT12	25 1/4	44 1/2
24	6	(Prefix)-24-06-HT12	28 1/4	38 1/2
	9	(Prefix)-24-09-HT12	28 1/4	41 1/2
	12	(Prefix)-24-12-HT12	28 1/4	44 1/2
	18	(Prefix)-24-18-HT12	28 1/4	50 1/2

**Note:** Dimensions for reference only, when critical contact factory.

### 3" Horizontal Expanding Tee

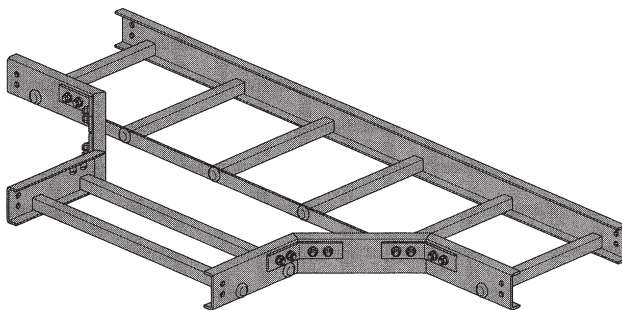

Two pair of splice plates with SS6 hardware included

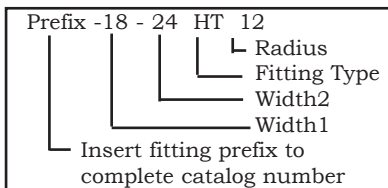
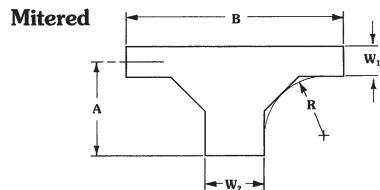

Tray Width		Catalog No.	12" Radius	
W1 in.	W2 in.		A in.	B in.
6	9	(Prefix)-06-09-HT12	19 1/4	41 1/2
	12	(Prefix)-12-12-HT12	19 1/4	44 1/2
	18	(Prefix)-06-18-HT12	19 1/4	50 1/2
	24	(Prefix)-06-24-HT12	19 1/4	56 1/2
9	12	(Prefix)-09-12-HT12	20 3/4	44 1/2
	18	(Prefix)-09-18-HT12	20 3/4	50 1/2
	24	(Prefix)-09-24-HT12	20 3/4	56 1/2
12	18	(Prefix)-12-18-HT12	22 1/4	50 1/2
	24	(Prefix)-12-24-HT12	22 1/4	56 1/2
18	24	(Prefix)-18-24-HT12	25 1/4	56 1/2

**Note:** Dimensions for reference only, when critical contact factory.